

CARBIDE INSERTS

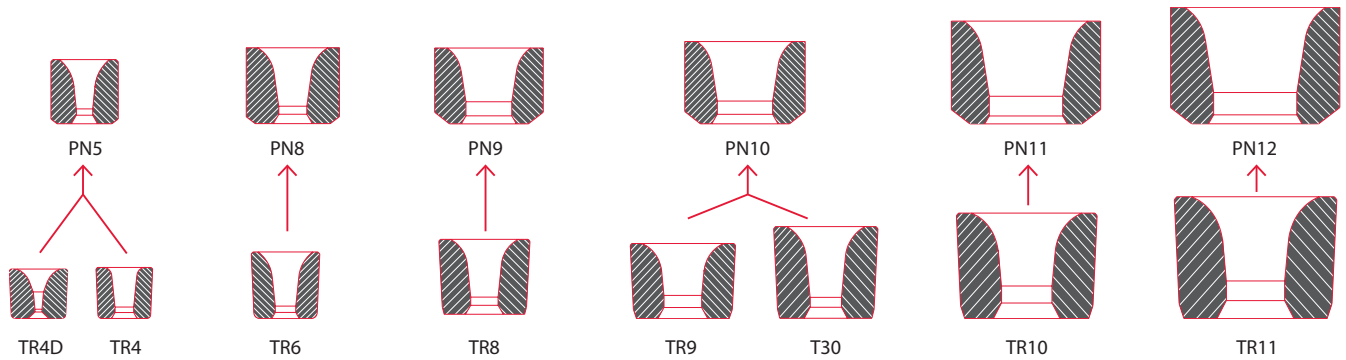

Drawing insert			
Draw Insert Type	Angles	Size Range	Stock Increment
TR4D	9°	.0060 - .0249 .0250 - .0590	* .0005
TR4	9°	.0300 - .0795 .0800 - .1950	.0005 .0010
	12°	.0300 - .0795 .0800 - .2300	.0005 .001
	16°	.0700 - .1179 .1180 - .2300	* .001
TR6	8°	.1580 - .3340	.001
	12°	.1580 - .3500	.001
	16°	.1500 - .1849 .1850 - .3490	* .001
TR8	12°	.2100 - .5120	*
	16°	.1780 - .2950	*
	18°	.3500 - .5120	*
T30	10°	.1930 - .4920	*
	12°	.2560 - .6500	*
TR9	18°	.5000 - .6500	*
TR10	12°	.6500 - .8850	*
	18°	.6500 - .8850	*
TR11	18°	.8850 - 1.250	*

Pressure insert			
Pressure Insert Type	Angles	Size Range	Increment
PN5	16°	.0300 - .0345	*
		.0350 - .0990	.0010
		.1000 - .1990	.0020
		.2000 - .2500	.0050
PN8	16°	.2510 - .2800	*
		.2800 - .4300	*
PN9	16°	.4350 - .6250	*
PN10	16°	.3000 - .7800	*
PN11	16°	.7850 - 1.145	*

Tolerance drawing inserts		
Size Range	Bearing Length	Internal Diameter
.0100 - .0199	20 - 50 %	+0.000 / -.0002
.0200 - .0249	25 - 50 %	+0.0000 / -.0003
.0250 - .0299	25 - 50 %	+0.0000 / -.0004
.0300 - .0999	30 - 50 %	+0.0000 / -.0005
.1000 - .1969	30 - 50 %	+0.0000 / -.0010
.1970 - .2959	25 - 45 %	+0.0000 / -.0010
.2960 - .3939	20 - 40 %	+0.0000 / -.0010
.3940 - .4999	20 - 35 %	+0.0000 / -.0010
.5000 >	20 - 30 %	+0.0000 / -.0010

Insert geometries listed are standard.
Stock increment sizes have faster lead-time.

Other diameters, approach angles, bearing lengths and tolerances available upon request.

* Sizes made to order from available raw material.



CARBIDE INSERTS

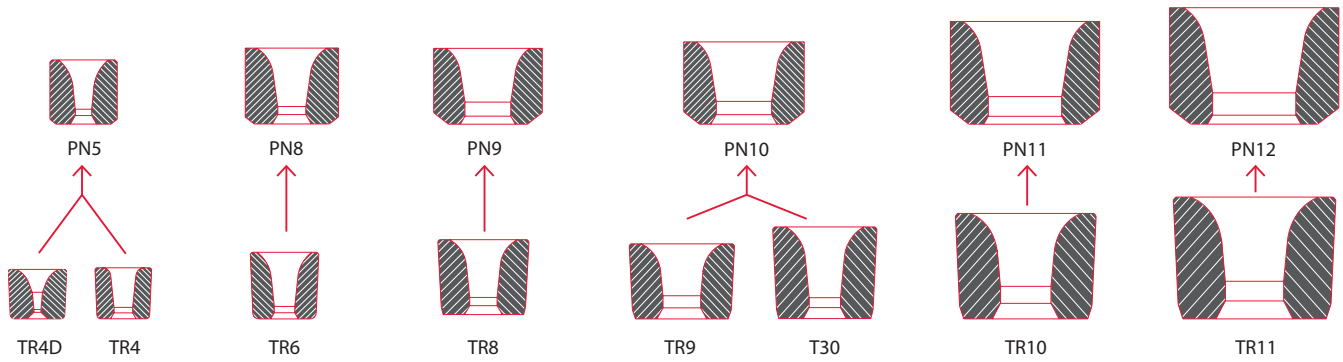

Drawing insert			
Draw Insert Type	Angles	Size Range	Stock Increment
TR4D	9°	0.15 - 0.64 0.65 - 1.50	* 0.01
TR4	9°	0.75 - 1.99 2.00 - 5.00	0.01 0.02
	12°	0.75 - 1.99 2.00 - 4.98 5.00 - 5.85	0.01 0.02 0.05
	16°	1.80 - 2.99 3.00 - 5.85	* 0.05
TR6	8°	4.00 - 8.45	0.05
	12°	4.00 - 8.90	0.05
	16°	3.80 - 5.49 5.50 - 8.90	* 0.05
TR8	12°	5.30 - 13.00	*
	16°	4.50 - 7.50	*
	18°	6.00 - 13.00	*
T30	10°	4.90 - 12.50	*
	12°	6.50 - 16.50	*
TR9	18°	12.60 - 16.50	*
TR10	12° / 18°	16.50 - 22.50	*
TR11	18°	22.50 - 32.00	*

Pressure insert			
Pressure Insert Type	Angles	Size Range	Increment
PN5	16°	0.75 - 0.99	*
		1.00 - 2.54	0.02
		2.55 - 6.05	0.05
		6.06 - 7.50	*
PN8	16°	4.80 - 11.00	*
PN9	16°	7.25 - 16.00	*
PN10	16°	6.00 - 20.00	*
PN11	16°	18.40 - 29.00	*

Tolerance drawing inserts		
Size Range	Bearing Length	Internal Diameter
0.15 - 0.499	20 - 50 %	+ 0.002 / - 0.002
0.50 - 0.649	25 - 50 %	+ 0.003 / - 0.003
0.65 - 0.749	25 - 50 %	+ 0.000 / - 0.010
0.75 - 2.499	30 - 50 %	+ 0.000 / - 0.010
2.50 - 4.999	30 - 50 %	+ 0.010 / - 0.010
5.00 - 7.499	25 - 45 %	+ 0.010 / - 0.010
7.50 - 9.99	20 - 40 %	+ 0.010 / - 0.010
10.00 - 12.69	20 - 35 %	+ 0.010 / - 0.010
12.70 >	20 - 30 %	+ 0.010 / - 0.010

Insert geometries listed are standard.
Stock increment sizes have faster lead-time.

Other diameters, approach angles, bearing lengths and tolerances available upon request.

* Sizes made to order from available raw material.

